

Field-Cycling MRI with 0.5T Detection

David J. Lurie, Gareth R. Davies, James M.S. Hutchison and Margaret A. Foster

Department of Bio-Medical Physics & Bio-Engineering, University of Aberdeen, Foresterhill, Aberdeen AB25 2ZD, Scotland, UK

For a number of years we have used magnetic field-cycling in combination with MRI. Our initial application was in combination with the Overhauser effect in order to image the distribution of free radicals in biological samples and living animals, using a method called field-cycled proton-electron double-resonance imaging (FC-PEDRI). We have also used field-cycling MRI to perform relaxometric imaging, and have demonstrated the well known quadrupole dips in the muscle tissue of volunteers. We are currently building a field-cycling MRI system with detection at almost 0.5 tesla, for use in free radical imaging and relaxometric studies.

In FC-PEDRI the magnetic field is first switched to the low evolution field, B_0^E , and the sample's EPR is irradiated. Due to the Overhauser effect there is a transfer of polarisation from electron to nuclear spins (protons) in parts of the sample containing free radical molecules. The field is then switched to the higher detection field, B_0^D , at which the gradients are applied and the NMR signal is detected. Regions of the sample in which the proton polarisation was changed by the Overhauser effect will exhibit altered intensity in the final image, revealing the distribution of the free radical.

Simulations of FC-PEDRI have shown that the optimum B_0^E value is around 5 mT, with EPR irradiation at around 100 MHz. The signal-to-noise ratio (SNR) in any small-sample field-cycling experiment is predominantly determined by the value of B_0^D , so this should be as high as possible. We have previously constructed and used an FC-PEDRI imager with a detection field of 59 mT (NMR detection at 2.5 MHz), which gave the expected 6-fold improvement in SNR over a 10 mT fixed-field experiment. Our new imager, with detection at 450 mT, should achieve a further 8-fold improvement in SNR.

The magnet system is illustrated in the figure. The $B_0^D = 450$ mT field is provided by a superconducting magnet (inner bore 80 cm). Inside this is a resistive coil assembly comprising a field-offset coil, gradient/shim coils and an active-shield coil, the latter preventing eddy currents in the cryostat of the superconducting magnet. The coil assembly has an inner diameter of 12 cm, making the system suitable for imaging mice or rats. To switch the field at the sample to the typical B_0^E value of 5 mT, the field-offset and active-shield coils are driven with a current of 870 A, provided by a custom-built power supply amplifier (Copley Controls, Inc.). This can be achieved in 40 ms.

In addition to FC-PEDRI, the new system will also be capable of field-cycling relaxometry measurements on samples up to ~300 ml volume, or of relaxometric imaging studies, making it a unique, flexible instrument.

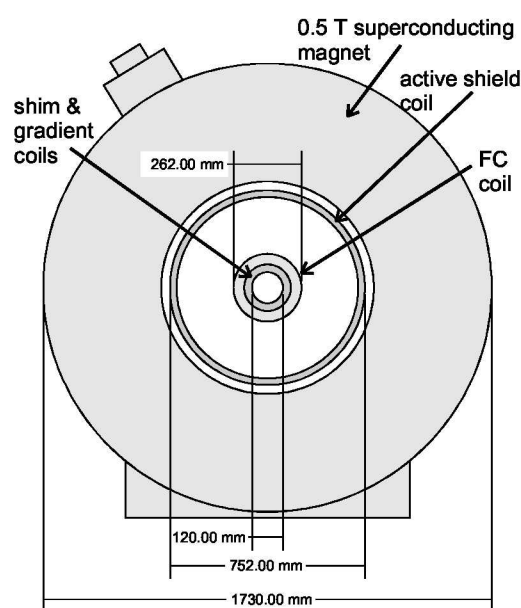

450 mT FC magnet system